

MESSRS : All the companies

Instruction Manual

CUSTOMER PRODUCT NAME :

TDK PRODUCT NAME : DC/DC CONVERTER UNIT ALD Series

***Notice**

Instruction Manual is not contract. This is only technical data.

This technical data may change about internal description without any notice.

When you design final product please request us Specification through our sales or distributors.

After you receive the Specification, the contract is effective on signature of the Specification.



TDK-Lambda Corporation

PREPARED BY	APPROVED BY	AUTHORIZED BY
Sep.7th.2009 K.Imai	Sep.7th.2009 K.Yamaishi	Sep.7th.2009 H.Masuoka

DWG.No.	CTR-3658-X
---------	------------



Precautionary Notes Regarding the Use of This Converter

When using this product, give due consideration to the precautionary notes described below and ensure a safe design. Inappropriate use may result in electric shock, injury or fire.

Caution

- This product is designed for driving LED backlight systems.
Do not use it with any other load.
- Store this product under the conditions defined in the specification document.
- Do not store this product in an environment where dust, dirt or corrosive gas (salt, acid, base, etc.) is present.
- This product is designed for use with general electronic equipment.
If it is to be used with medical equipment that directly affects human life or for the control of transportation equipment to which passengers entrust their lives, provide thorough fail-safe measures.
- Avoid using this product under high temperatures or high humidity or in an environment in which dust, dirt or any corrosive gas (salt, acid, base, etc.) is present.
Also, be careful not to allow the formation of dew condensation. It may result in damage or electric shock.
- If the product does not have a built-in protective circuit (circuit breaker, fuse, etc.), it is recommended that a fuse be used at the input stage to prevent the occurrence of smoke or fire in the event of a malfunction.
Even when the product has a built-in protective circuit (circuit breaker, fuse, etc.), the circuit may not function properly due to inappropriate operating conditions or power-supply capacity. It is recommended that an appropriate protective circuit (circuit breaker, fuse, etc.) be provided separately from the built-in circuit.
- Use the product only within the specified input voltage, output power, output voltage and operating temperature ranges. Exceeding these values may result in damage, etc.
- Provide a measure for the prevention of surge voltage due to lightning, etc.
Abnormal voltage may result in damage, etc.
- This product is not designed to provide resistance to radiation.
- Ripples could be superimposed on the voltage and the current in the input source connected to the inverter, depending on the impedance in the input source, wiring, etc.
When you select an input source, please check waveforms, etc. on the final set.

Handling Precautions

- Do not stack multiple products on top of one another.
- Do not allow the product to come in contact with tools, etc.
- Do not apply excessive stress during installation.
It may cause chipping and cracking, resulting in damage, etc.
- Please do not use the product, if it has been dropped because there is the possibility of component damage.



DC-DC Converter Unit ALD Series: Instruction Manual

1 Product Name

ALD - 2 1 4 0 1 2 P J 1 1 1

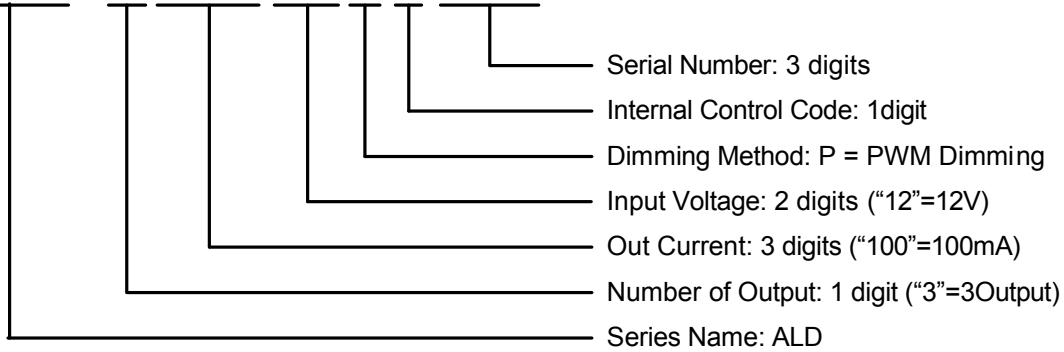

2 Product Summary

*The ALD Series Lineup is as follows:

Item Name	# of Strings	Input Voltage	Output Current	Burst Freq.	Dimming		Vopen max	Dimensions
		(Vdc)	(mA)	(Hz)	Analog (V)	PWM DC(V)	(V)	
ALD-214012PJ111	2	10.8~13.2	140	150	2.5~0	2.5~0	44	85.0(typ.)x21.5(typ.)x5.0(max)
ALD-310012PJ125	2	10.8~13.2	100	220	*1	0~2.5	42	85.0(typ.)x21.5(typ.)x5.5(max)
ALD-414012PJ126	4	10.8~13.2	140	150	2.5~0	2.5~0	44	100.0(typ.)x50.0(typ.)x5.2(max)
ALD-514012PJ127	5	10.8~13.2	140	150	2.5~0	2.5~0	44	100.0(typ.)x50.0(typ.)x5.2(max)

*1 Though we recommend resistor dimming(Rbr), Analog amplitude dimming is acceptable in the 0V to 4V range.



DC-DC Converter Unit ALD Series: Instruction Manual

3 Terminal Connection

*Please be careful when connecting the input terminal. The converter may be damaged if there is a mistake in the terminal connection or polarity.

The connector used for each product is different so make sure that you use only the connector indicated in the Product Specifications.

Please refer to Table 3-1 which indicates the connector to be used with each product.

Table 3-1

Product Name	Input Connector	Corresponding	Vendor	Output Connector	Corresponding	vendor
ALD-214012PJ111	SM08B-SRSS-TB	SHR-08V-S-B	JST	SM06B-SRSS-TB	SHR-06V-S-B	JST
ALD-310012PJ125	53261-0871	51021-0800	molex	SM06B-SRSS-TB	SHR-06V-S-B	JST
ALD-414012PJ126	SM14B-SRSS-TB	SHR-14V-S-B	JST	SM10B-SRSS-TB	SHR-10V-S-B	JST
ALD-514012PJ127	SM14B-SRSS-TB	SHR-14B-S-B	JST	SM10B-SRSS-TB	SHR-10V-S-B	JST

Input connector functions are explained and connection diagrams are provided in Tables 3-2~3-4 and Figs. 3-1~3-3.

*The Vbr terminal has a low internal impedance setting because the ALD series takes dimming by resistor into consideration.

If you apply voltage to the Vbr terminal, we recommend a voltage follower connection or a low output impedance connection.

When you have no choice but to connect a high impedance circuit to Vbr terminal, please consider Vbr input impedance indicated in Figs. 3-4~3-6.

DC-DC Converter Unit ALD Series: Instruction Manual

Fig. 3-1 ALD-214012PJ111

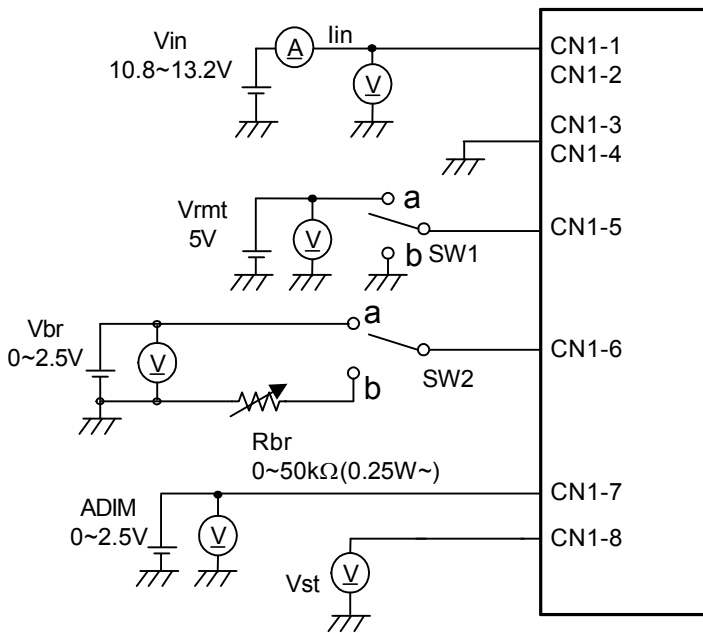
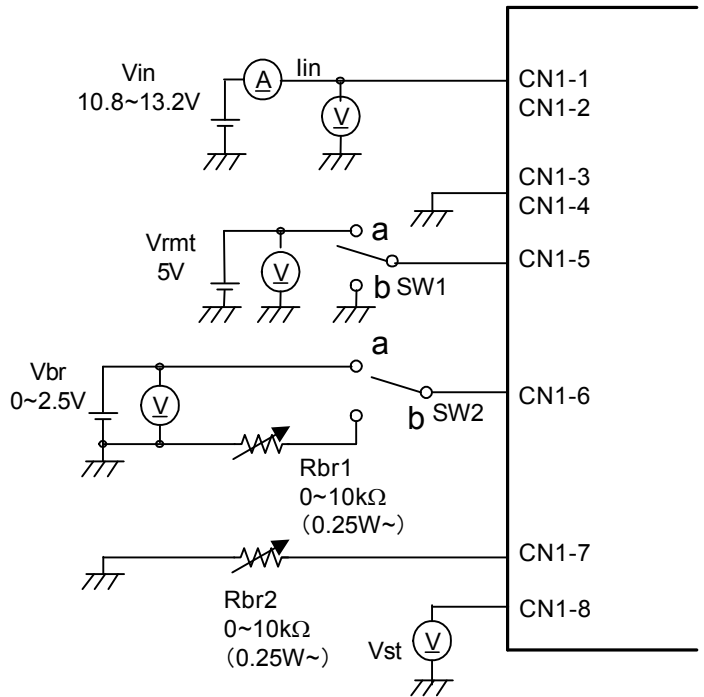

Fig.3-2 ALD-310012PJ125



*The connector used is different for each product. Please refer to the following table.

Table 3-2 ALD-214012PJ111

CN1: SM08B-SRSS-TB / JST			
Pin	Symbol	Specification	Note
CN1-1 CN1-2	Vin	10.8~13.2(Vdc)	Input Voltage
CN1-3 CN1-4	GND	0(V)	GND
CN1-5	Vrmt	0~0.4(Vdc) : OFF 2.5~Vin(Vdc): ON	ON/OFF Control
CN1-6	Vbr	0~2.5(Vdc)	PWM dimming*1
	Rbr	0~50(kΩ)	
CN1-7	ADIM	0~2.5(Vdc)	Analog dimming*2
CN1-8	Vst (Output)	0(V) / 5(Vdc)	Alarm output*3

*1 PWM dimming max. brightness is Vbr=0V or Rbr=0Ω.
PWM dimming min. brightness is Vbr=2.5V or Rbr=50kΩ.

*2 Analog dimming max. brightness is ADIM=0V and dimming min. brightness is ADIM=2.5V.

*3 Alarm output is 0V at normal operation and 5V at abnormal operation.

Table3-3 ALD-310012PJ125

CN1: 53261-0871 / MOLEX			
Pin	Symbol	Specification	Note
CN1-1 CN1-2	Vin	10.8~13.2(Vdc)	Input Voltage
CN1-3 CN1-4	GND	0(V)	GND
CN1-5	Vrmt	0~0.4(Vdc) : OFF 2.5~Vin(Vdc): ON	ON/OFF Control
CN1-6	Vbr	0~2.5(Vdc)	PWM dimming*4
	Rbr1	0~10(kΩ)	
	PWM	0(V) : OFF / 3.3(V) : ON	
CN1-7	Rbr2	0~10(kΩ)	Analog dimming*5
CN1-8	Vst (Output)	0(V) / 5(Vdc)	Alarm output*6

*4 PWM dimming max. brightness is Vbr=2.5V or Rbr=10kΩ.
PWM dimming min. brightness is Vbr=0V,Rbr=0Ω.
PWM pulse is acceptable, High active and low inactive.

*5 Resistor dimming max. brightness is Rbr2=10kΩ.
Resistor dimming min. brightness is Rbr2=0Ω.

Also external DC voltage is acceptable.
Analog dimming max. brightness is Rbr=0V.
Analog dimming min. brightness is Rbr=4V.

*6 Alarm output is 0V at normal operation and 5V at abnormal operation.

DC-DC Converter Unit ALD Series: Instruction Manual

Fig. 3-3 ALD-414012PM126, ALD-514012PM127

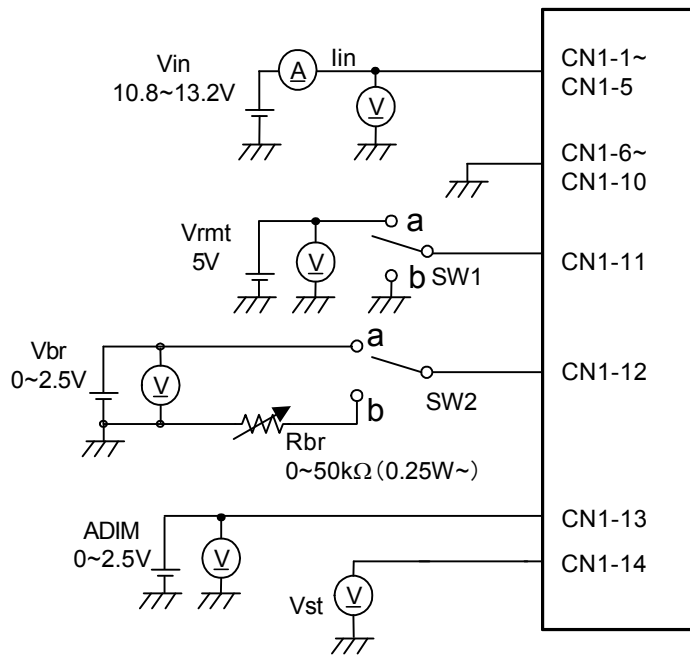

*The connector used is different for each product. Please refer to the following table.

Table 3-4 ALD-414012PJ126
ALD-514012PJ127

CN1: SM14B-SRSS-TB /JST

Pin	Symbol	Specification	Note
CN1-1			
CN1-2			
CN1-3	V_{in}	10.8~13.2(Vdc)	Input Voltage
CN1-4			
CN1-5			
CN1-6			
CN1-7			
CN1-8	GND	0(V)	GND
CN1-9			
CN1-10			
CN1-11	V_{rmt}	0~0.4(Vdc) : OFF 2.5~ V_{in} (Vdc): ON	ON/OFF Control
CN1-12	V_{br}	0~2.5(Vdc)	PWM dimming*7
	R_{br}	0~50(k Ω)	
CN1-13	ADIM	0~2.5(Vdc)	Analog dimming*8
CN1-14	V_{st} (Output)	0(V) / 5(Vdc)	Alarm output*9

*7 PWM dimming max. brightness is $V_{br}=0V$ or $R_{br}=0\Omega$.
PWM dimming min. brightness is $V_{br}=2.5V$ or $R_{br}=50k\Omega$.

*8 Analog dimming max. brightness is ADIM=0V.
Analog dimming min. brightness is ADIM=2.5V.

*9 Alarm output is 0V at normal operation and 5V at abnormal operation.



DC-DC Converter Unit ALD Series: Instruction Manual

*Output connector is different for each product. Please refer to the following table.

Table 3-5 ALD-214012PJ111

CN3: SM06B-SRSS-1 /JST

Pin	Symbol	Note
CN3-1	LED_C2	line2-cathode side
CN3-2	LED_A2	line2-anode side
CN3-3	LED_A1	line1-anode side
CN3-4	LED_C1	line1-cathode side
CN3-5	N.C.	Not connected
CN3-6	N.A.	Tie to GND internally

Table 3-6 ALD-310012PJ125

CN2: SM06B-SRSS-1 /JST

Pin	Symbol	Note
CN2-1	LED_A3	line3-anode side
CN2-2	LED_A2	line2-anode side
CN2-3	LED_A1	line1-anode side
CN2-4	LED_C1	line1-cathode side
CN2-5	LED_C2	line2-cathode side
CN2-6	LED_C3	line3-cathode side

Table 3-7 ALD-414012PJ126

CN3: SM10B-SRSS-1 /JST

Pin	Symbol	Note
CN3-1	LED_C4	line4-cathode side
CN3-2	LED_A4	line4-anode side
CN3-3	LED_A3	line3-anode side
CN3-4	LED_C3	line3-cathode side
CN3-5	LED_C2	line2-cathode side
CN3-6	LED_A2	line2-anode side
CN3-7	LED_A1	line1-anode side
CN3-8	LED_C1	line1-cathode side
CN3-9	N.C.	Not Connected
CN3-10	N.C.	Not Connected

Table 3-8 ALD-514012PJ127

CN3: SM10B-SRSS-1 /JST

Pin	Symbol	Note
CN3-1	LED_C5	line5-cathode side
CN3-2	LED_A5	line5-anode side
CN3-3	LED_A4	line4-anode side
CN3-4	LED_C4	line4-cathode side
CN3-5	LED_C3	line3-cathode side
CN3-6	LED_A3	line3-anode side
CN3-7	LED_A2	line2-anode side
CN3-8	LED_C2	line2-cathode side
CN3-9	LED_C1	line1-cathode side
CN3-10	LED_A1	line1-anode side

*Vst terminal is alarm output terminal. Vst outputs around 0V at steady state, around 5V at open LED condition. Alarm output terminal circuit is different depending on the model.

If you use the alarm output signal of the DC-DC converter, we recommend high input impedance device like a operation amplifier or a comparator input.

If you use the Vst terminal(Alarm output) for emitting a signal, please take Vst terminal output impedance into consideration.

Fig. 3-4
ALD-214012PJ111

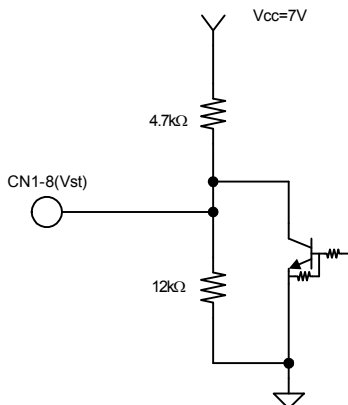

fig. 3-5
ALD-310012PJ125

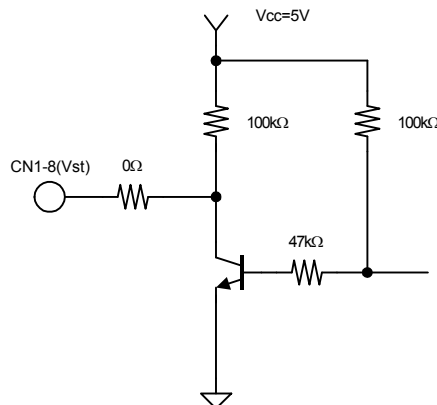
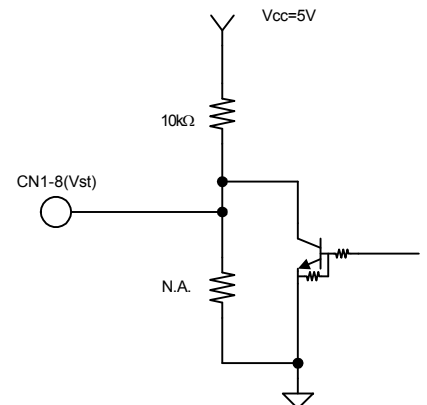

Fig. 3-6
ALD-414012PJ126
ALD-514012PJ127





DC-DC Converter Unit ALD Series: Instruction Manual

*The PWM dimming circuit is different for each product. Please confirm the specifications for each product.

Fig. 3-7 ALD-214012PJ111

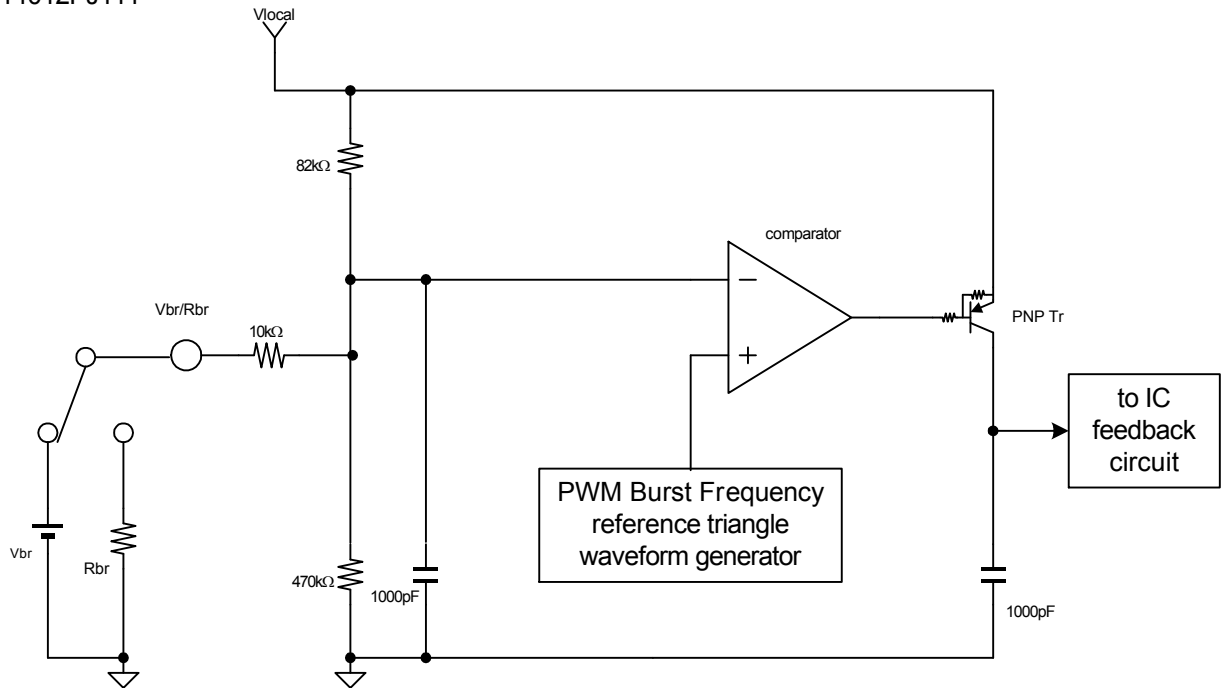

* Maximum brightness is achieved $V_{br}=0V$ or $R_{br}=0\Omega$. Minimum brightness is achieved $V_{br}=2.5V$ or $R_{br}=50k\Omega$.

Fig. 3-8 ALD-310012PJ125

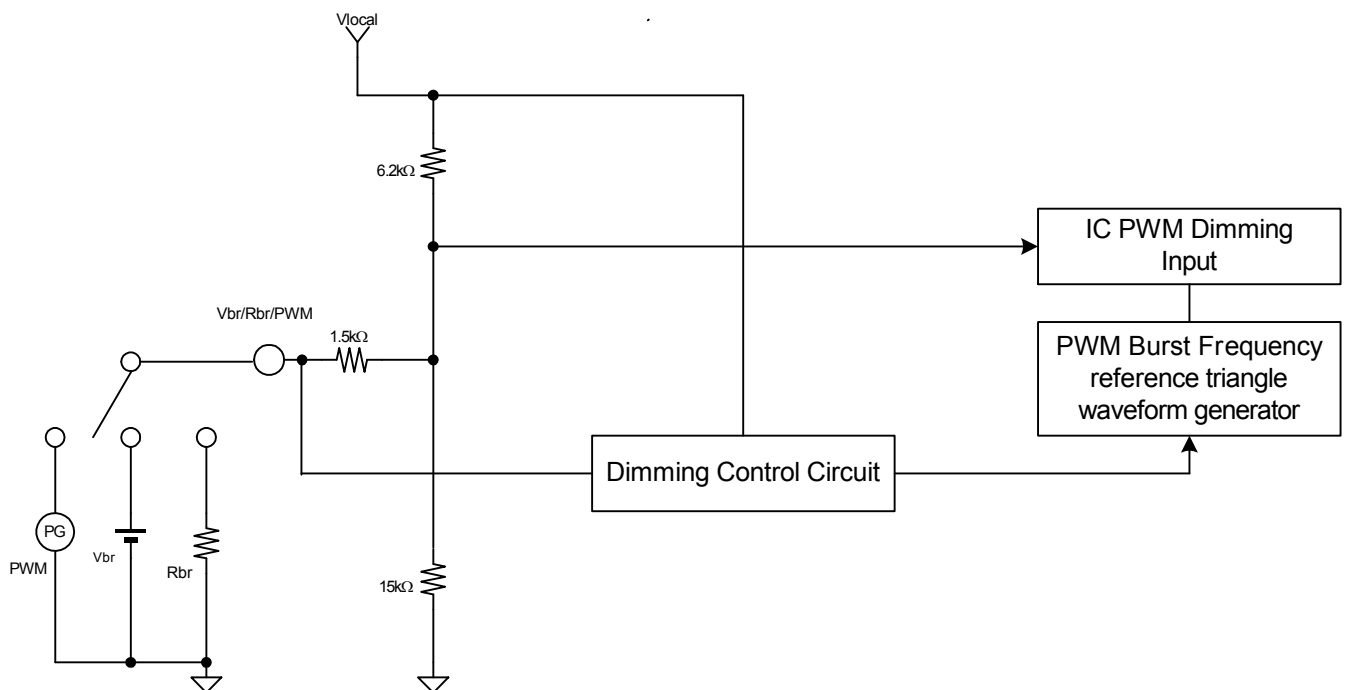

*Maximum brightness is achieved $V_{br}=2.5V$ or $R_{br}=10k\Omega$. Minimum brightness is achieved $V_{br}=0V$ or $R_{br}=0\Omega$. Also PWM pulse is acceptable. Active at 3.3V and inactive at 0V.



DC-DC Converter Unit ALD Series: Instruction Manual

Fig. 3-9 ALD-414012PJ126, ALD-514012PJ127

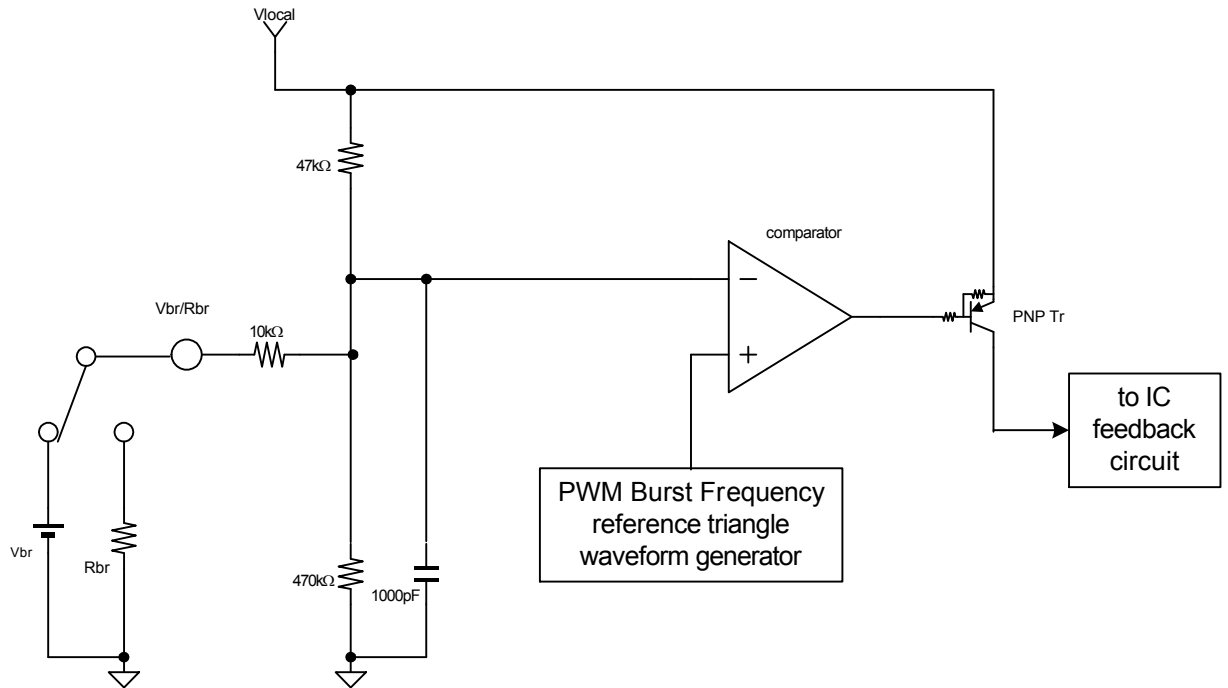

* Maximum brightness is achieved $V_{br}=0V$ or $R_{br}=0\Omega$. Minimum brightness is achieved $V_{br}=2.5V$ or $R_{br}=50k\Omega$.



DC-DC Converter Unit ALD Series: Instruction Manual

*We recommend that the converter GND terminal and LCD backlight frame connected to each other.
If you operate LCD backlight at floating, the converter may be damaged by contact discharge.
When contact discharge apply to the LCD backlight, Over voltage apply LED to the converter because LED is placed near the LCD backlight panel.
If the converter GND fixing terminal cannot be connected directly to the LCD backlight panel, please take whatever measure necessary to make sure that the converter GND terminal is same current potential as LCD backlight frame.

Fig. 3-8

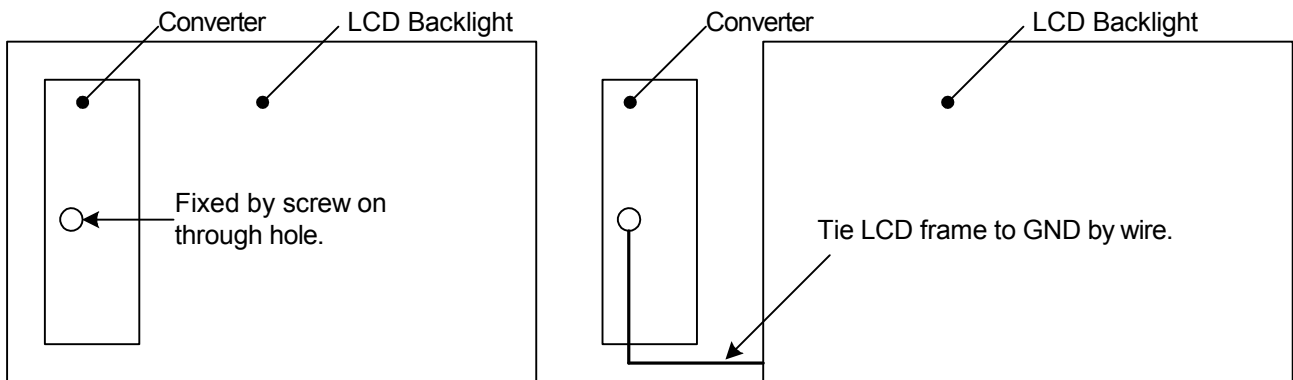

4 Noise Reduction

*The following noise system summarizes the converter noise generation.

- (1) Ripple noise between input terminals
- (2) Switching noise generated by main switch
- (3) Induction noise generated by inductor leakage flux

4-1 Ripple Noise between Input Terminals

The Input terminal of the ALD series has the following circuit Figs. 4-1~4-4 depending on the model.

Fig. 4-1 ALD-214012PJ111

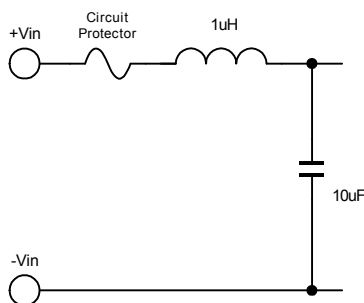
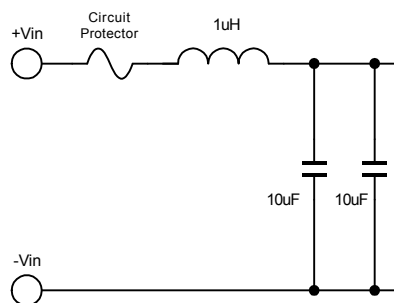

Fig. 4-2 ALD-310012PJ125





DC-DC Converter Unit ALD Series: Instruction Manual

Fig. 4-3 ALD-414012PJ126

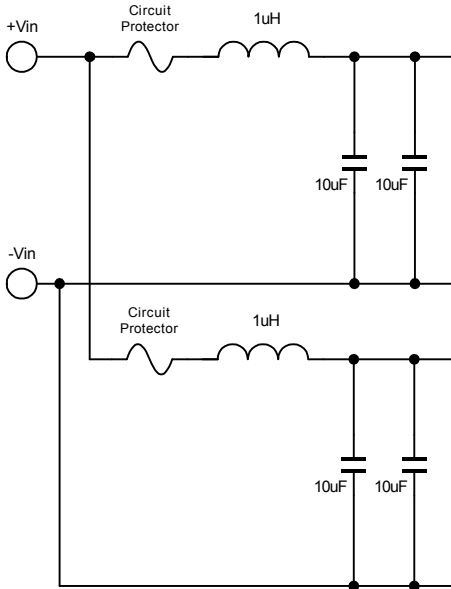
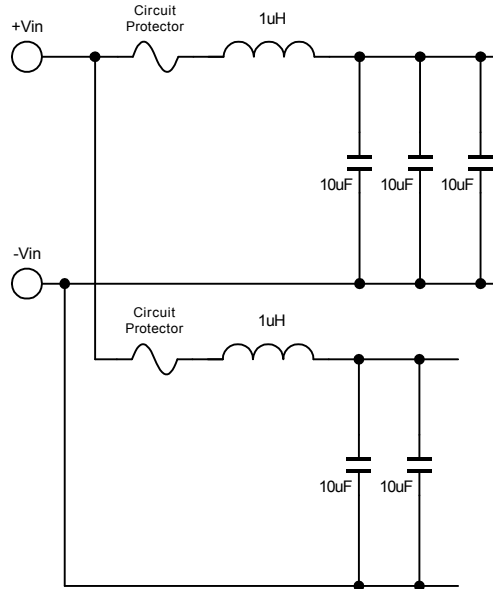
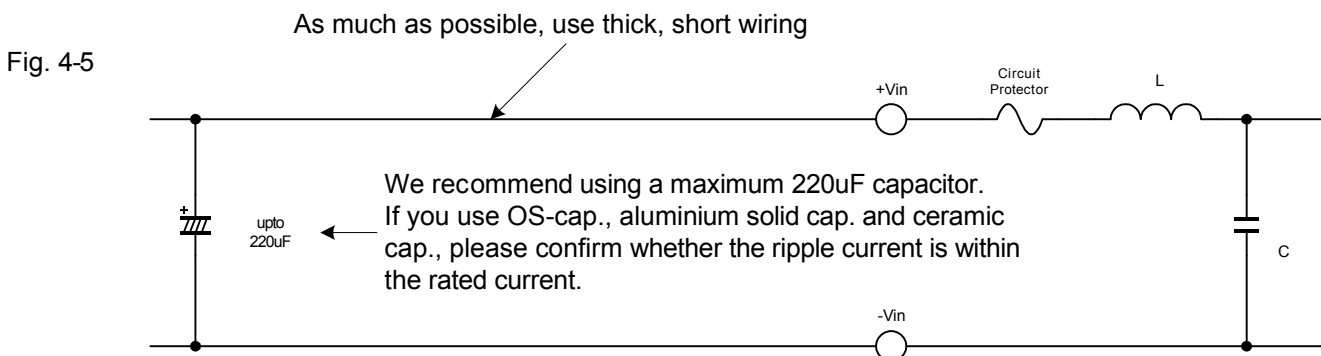

Fig. 4-4 ALD-514012PJ127



π -type low pass filter is available by attaching an external capacitor to the input terminal. This filter is effective against ripple voltage and current at the input terminal compared with no filter products. And this filter is not susceptible to ESR and capacitance because an inductor is on the input line. We evaluate ripple voltage and current as follows:
We attached a Nippon Chemicon type LXZ35V-1000uF(ϕ 12.5,L=20mm) 15cm from the converter. The ripple voltage and current is determined by external capacitance, ESR, wire length and wiring impedance. Please confirm ripple voltage is within the rated voltage and ripple current is within rated current of circuit protector before using.





4-2 Switching Noise Generated by Main Switch

The ALD series employs boost up chopper topology.

Switching frequency is between 400kHz and 1.5MHz. It depends on the model.

Internal PWM burst frequency is around 150Hz to 250Hz.

Noise may appear at basic frequency, 3times, 5times and odd number times of frequency.

Please confirm that the final set is not affected by this noise.

We designed the pcb to minimize the pulse line on the layout.

Noise filter insertion and multistage low pass filter insertion at input terminal is effective for reduction of power line noise.

For radiation noise the following situation needs to be taken into consideration:

When main switch turns on, the pulse current flows from the input cap. to the inductor and main switch.

When main switch turns off, the pulse current flows from the input cap. to the inductor, diode and output cap..

When the control IC drives the main switch, the impulse current flows as charge or discharge gate capacitance.

For final products sensitive to the noise, effectiveness can be expected by using a shield and by placement which avoids this area.

4-3 Induction Noise Generated by Inductor Leakage Flux

In the ALD series, the choke inductor is the component that generates leakage flux.

The inductor may affect the high impedance line of near field because of the huge leakage flux.

Please be careful don't place signal path near field of inductor.

And if you shield leakage flux by high permeability material at close range of inductor top, eddy current losses by leakage flux occurs. As a result, it reduces circuit efficiency and causes unexpected heat up.

Please be sure to keep enough space between shield materials and the inductor.



DC-DC Converter Unit ALD Series: Instruction Manual

5 Dimming Function

*The ALD series is able to adjust the PWM dimming brightness by the Vbr/Rbr terminal and current amplitude dimming by the ADIM terminal. Positive logic or negative logic, dimming function and dimming polarity is different by the model.

5-1 ALD-214012PJ111

Fig. 5-1 PWM DC dimming characteristics(Vbr vs Iout)

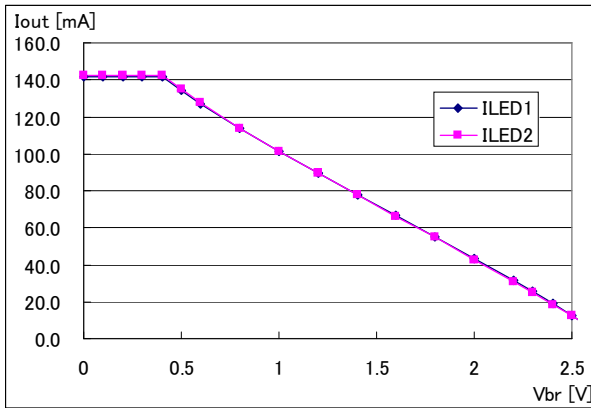

Fig. 5-2 PWM Resistor dimming characteristics(Rbr vs Iout)

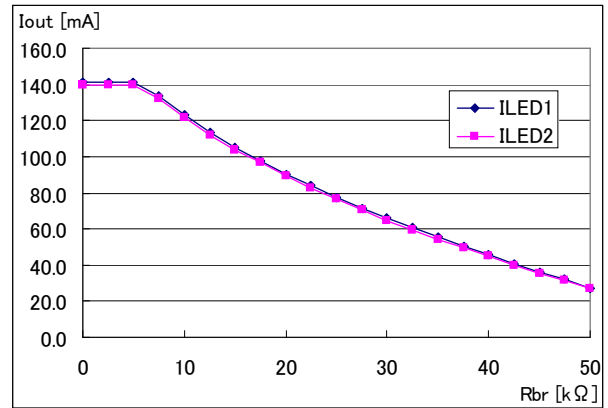
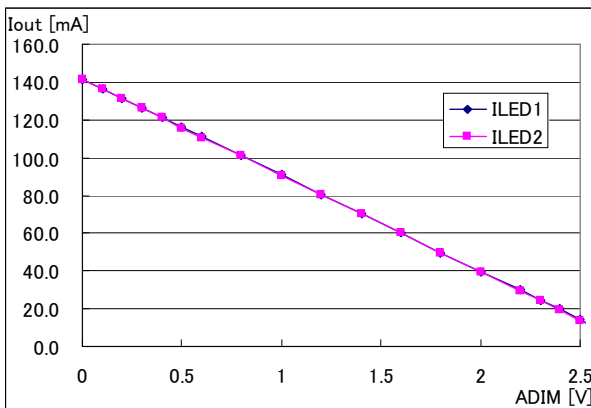

Fig. 5-3 Current Amplitude dimming characteristics(ADIM vs Iout)



5-2. ALD-310012PJ125

Fig 5-4 PWM DC Dimming Characteristics(Vbr1 vs Iout)

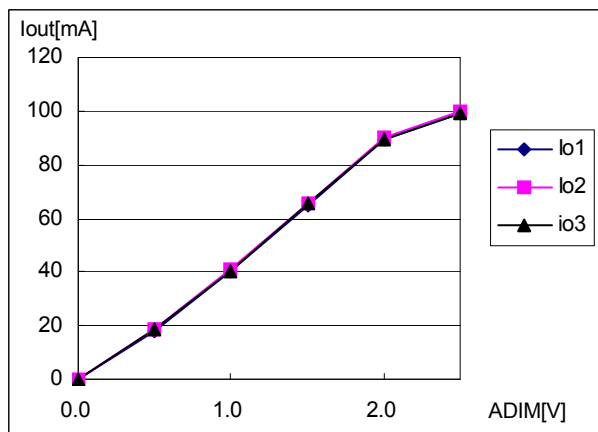
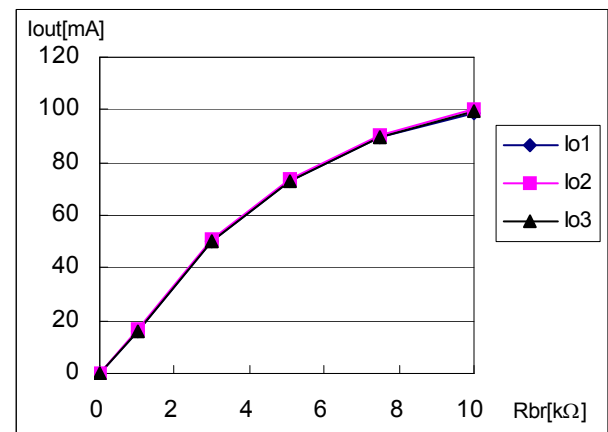

Fig 5-5 PWM Resistor Dimming Characteristics(Rbr1 vs Iout)



DC-DC Converter Unit ALD Series: Instruction Manual

Fig.5-6 Current Amplitude Dimming Characteristics(Vbr2 vs Iout)

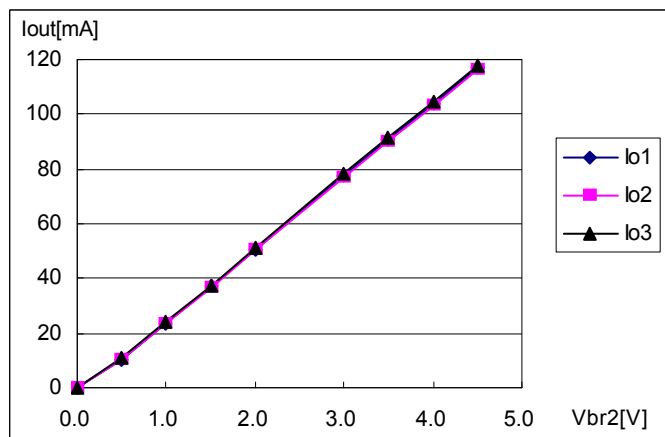
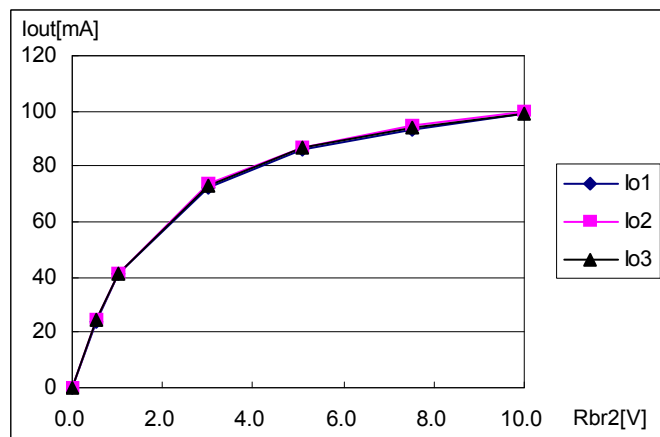

Fig.5-7 Current Resistor Dimming Characteristics(Rbr2 vs Iout)



5-3 ALD-414012PJ126 , ALD-514012PJ127

Fig. 5-8 PWM DC dimming characteristics(Vbr vs Iout)

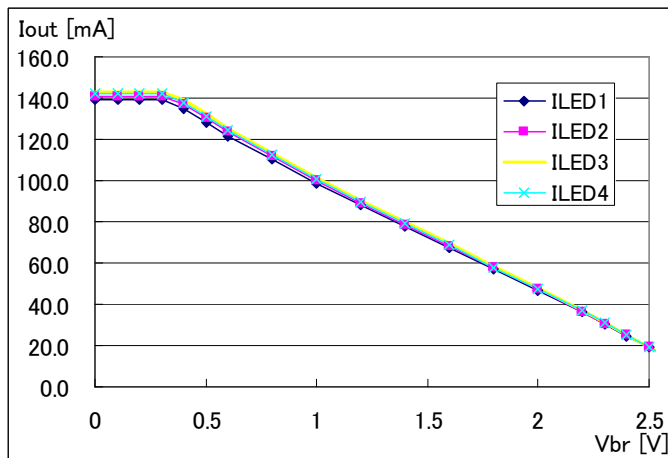

Fig. 5-9 PWM Resistor dimming characteristics(Rbr vs Iout)

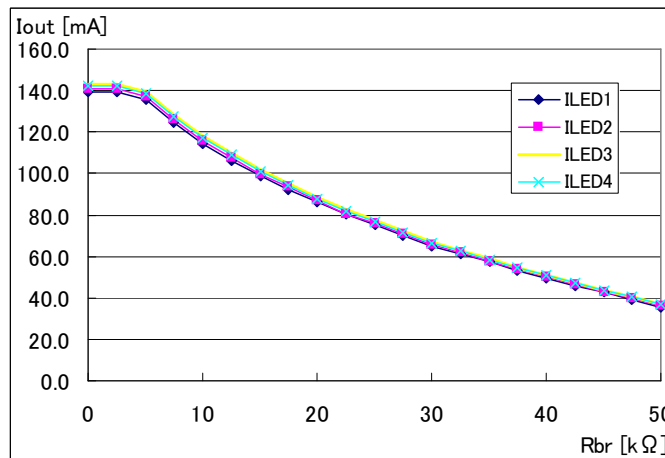
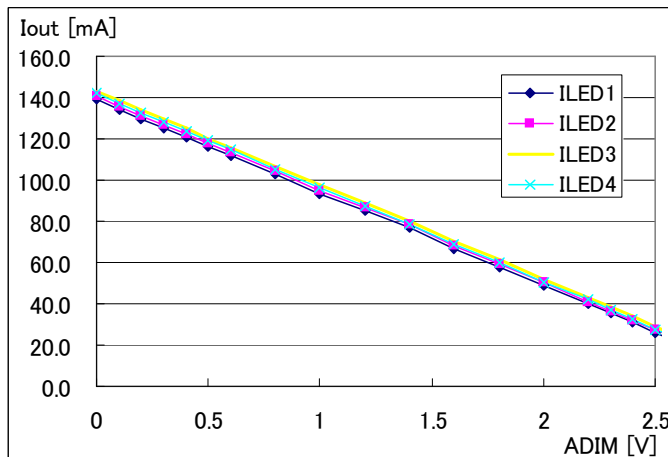

Fig. 5-10 Current Amplitude dimming characteristics(ADIM vs Iout)



*The dimming characteristics of ALD-414012PJ126 and ALD-514012PJ127 are almost the same.



6 Protection Function

*The ALD series is equipped with the following protection circuits:

- (1) Open LED protection circuit (Alarm output)
- (2) Over Voltage protection circuit(Alarm output)
- (3) Input Over Current protection circuit(Fuse blows)

6-1 Open LED Protection Circuit

6-1-1 ALD-214012PJ111, ALD-414012PJ126, ALD-514012PJ127

The Open LED protection circuit and the over voltage protection circuit are the same circuit.

If one of the LED strings is open, the opened string keeps working in an over voltage condition and the other strings work normally.

The alarm output is active(around 5V) when any string is in an open condition.

6-1-2 ALD-310012PJ125

ALD-310012PJ125 has build-in open LED protection circuit.

If one of the LED strings is open, the opened string turns off and the other strings work normally.

If all strings are open, the converter keeps working in an over voltage condition.

The alarm output is active(around 5V) when any string is in an open condition.

6-2 Over Voltage Protection Circuit

6-2-1 ALD-214012PJ111, ALD-414012PJ126, ALD-514012PJ127

When over voltage protection circuit works, the unit keeps on working at over voltage threshold voltage.

The alarm output is active(around 5V) when any strings work at over voltage condition.

If the unit switches from an over voltage condition to a normal condition, the alarm output automatically inactivates.

6-2-2 ALD-310012PJ125

ALD-310012PJ125 tries to adjust the each string current all the same when one of the LED strings open. If one of the LED strings is open, output voltage is increase intentionally in order to increase string current.

If the opened string voltage exceeds over voltage protection(OVP) threshold, the unit turns opened string off and other strings work normally.

After that output voltage return to steady voltage.

If all strings are open, once output voltage is increase up to OVP threshold.

The unit works at minimum on duty if the unit's output voltage exceed OVP threshold.

As a result, the unit output voltage is lower than OVP threshold.

The alarm output is active(around 5V) when any string is in an open condition.

Once alarm function is activated, the alarm output never automatically inactivates until remote on/off or restart power supply.

6-3 Input Over Current Protection Circuit

The ALD series has an internal over current protector for the input.

Please ensure power supply capacity on the specifications for proper operation of over current protector.

Please confirm input current on the final products doesn't exceed the standard value of the specifications in any conditions.

When you cannot guaranty the power supply capacity, please prepare other external over current protection device because the circuit protector may not work properly.



7 Alarm Output Function

*The ALD series has an alarm output function. The Alarm output is 0~1V at normal condition and around 5V at abnormal condition.

Please confirm the following precautions about the alarm output that is generated internally:

7-1 Recommended Power On/Off Sequence

*Turn On Sequence

- 1) apply input voltage
- 2) apply Vbr and ADIM voltage (recommend low impedance output like operation amplifier output etc.)
- 3) apply remote on/off voltage (recommend High signal at open collector or logic output)

*Please ignore alarm signal at turn on when you control external product by monitoring alarm output.
(please refer to next page:recommended sequence)

*Turn Off Sequence

- 1) turn off remote on/off voltage(recommend Low signal at open collector or logic output)
- 2) turn off Vbr and ADIM voltage (recommend low impedance output like operation amplifier output etc.)
- 3) turn off input voltage

*Please ignore alarm signal at turn off when you control external product by monitoring alarm output.
(please refer to next page:recommended sequence)

7-2 Turn on input voltage and remote on/off voltage simultaneously

*Turn On Sequence

When input voltage is lower than working voltage of IC, the alarm signal may activate.

When the rise time of input voltage is long, the alarm signal may activate.

Please ignore alarm signal at turn off when you control external product by monitoring alarm output.

(please refer to next page:recommended sequence)

*Turn Off Sequence

When input voltage is lower than working voltage of IC, alarm signal may activate.

When the fall time of input voltage is long, the alarm signal may activate.

Please ignore alarm signal at turn off when you control external product by monitoring alarm output.

(please refer to next page:recommended sequence)

7-3 Turn on or turn off remote control voltage slowly

*Turn On Sequence

When the rise time of remote on/off voltage is long, the alarm signal may activate.

We recommend slew rate apply to the remote on/off terminal is faster than $0.1V/\mu\text{sec}$.

*Turn Off Sequence

When the fall time of remote on/off voltage is long, the alarm signal may activate.

We recommend that the slew rate applied to the remote on/off terminal is faster than $0.1V/\mu\text{sec}$.

7-4 Actual Alarm Output Behavior

Alarm output behavior is different for each model.

Please confirm the alarm output function table for each model.



DC-DC Converter Unit ALD Series: Instruction Manual

***Recommended Power On/Off Sequence**

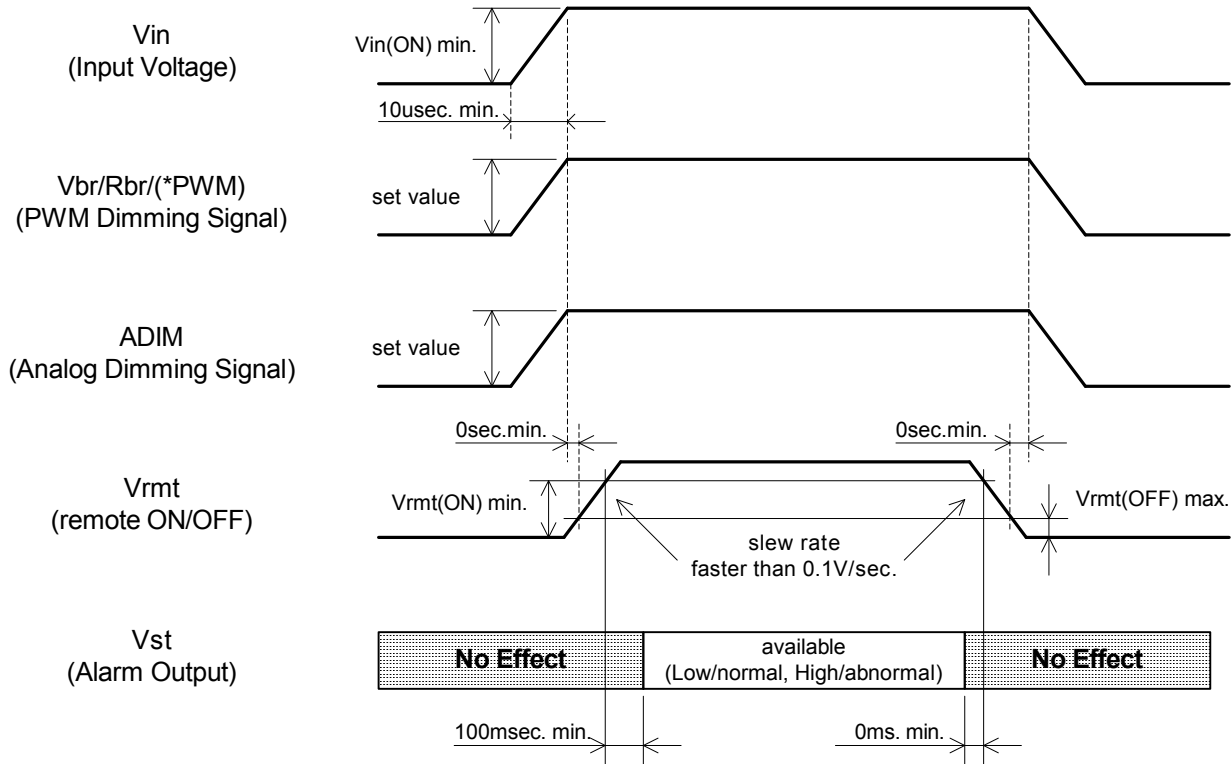

- $V_{in(ON) \min.}$: minimum of recommended working input voltage
- $V_{rrmt(ON) \min.}$: minimum V_{rrmt} on voltage
- $V_{rrmt(OFF) \max.}$: maximum V_{rrmt} off voltage

*ALD-310012PJ125 is acceptable PWM pulse signal. H-active and L-inactive.
 Other ALD series may have flicker at low duty PWM pulse operation. L-active and H-inactive.
 We don't recommend PWM pulse dimming except ALD-310012PJ125.

DC-DC Converter Unit ALD Series: Instruction Manual

8 Connection Diagram

Fig. 8-1 ALD-214012PJ111

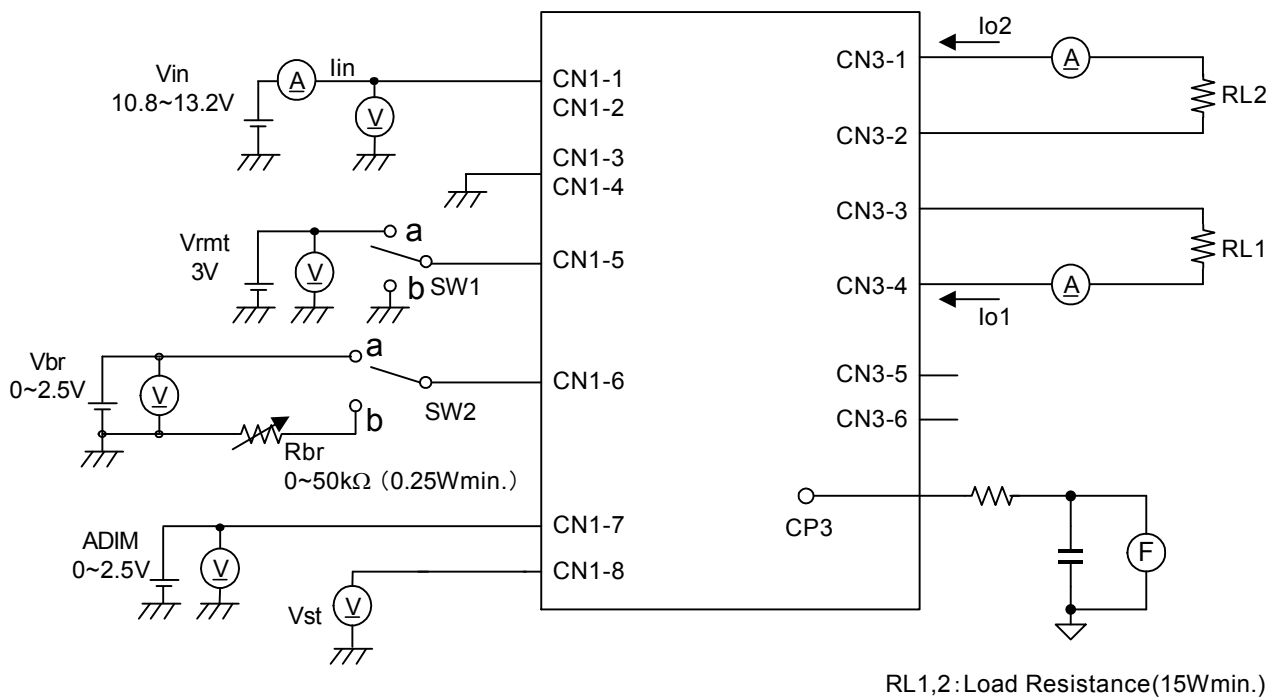

RL1,2: Load Resistance(15Wmin.)

Note 8-1 SW1 function

SW1	Unit Behavior
a	Working
b	Not Working
open	Not Working

Note 8-2 SW2 function

SW2	Unit Behavior
a	PWM DC Dimming V _{br} =0~2.5V
b	PWM Resistor Dimming R _{br} =0~50kΩ

* V_{br}=0V: maximum brightness
R_{br}=0Ω: maximum brightness

Note 8-3 Test Equipment

- (V) : DC Voltage Meter (ADVANTEST R6452A or equivalent)
- (A) : DC Current Meter (ADVANTEST R6452A or equivalent)
- (F) : Frequency Counter (ADVANTEST R6452A or equivalent)

Note 8-4 Protection Circuit

Load Condition	Alarm Output (CN1-8)	Latch Function
steady state	0.5V max.	no latch-up
1string open	4.5V min.	no latch-up
All strings open	4.5V min.	no latch-up

Fig. 8-2 ALD-310012PJ125

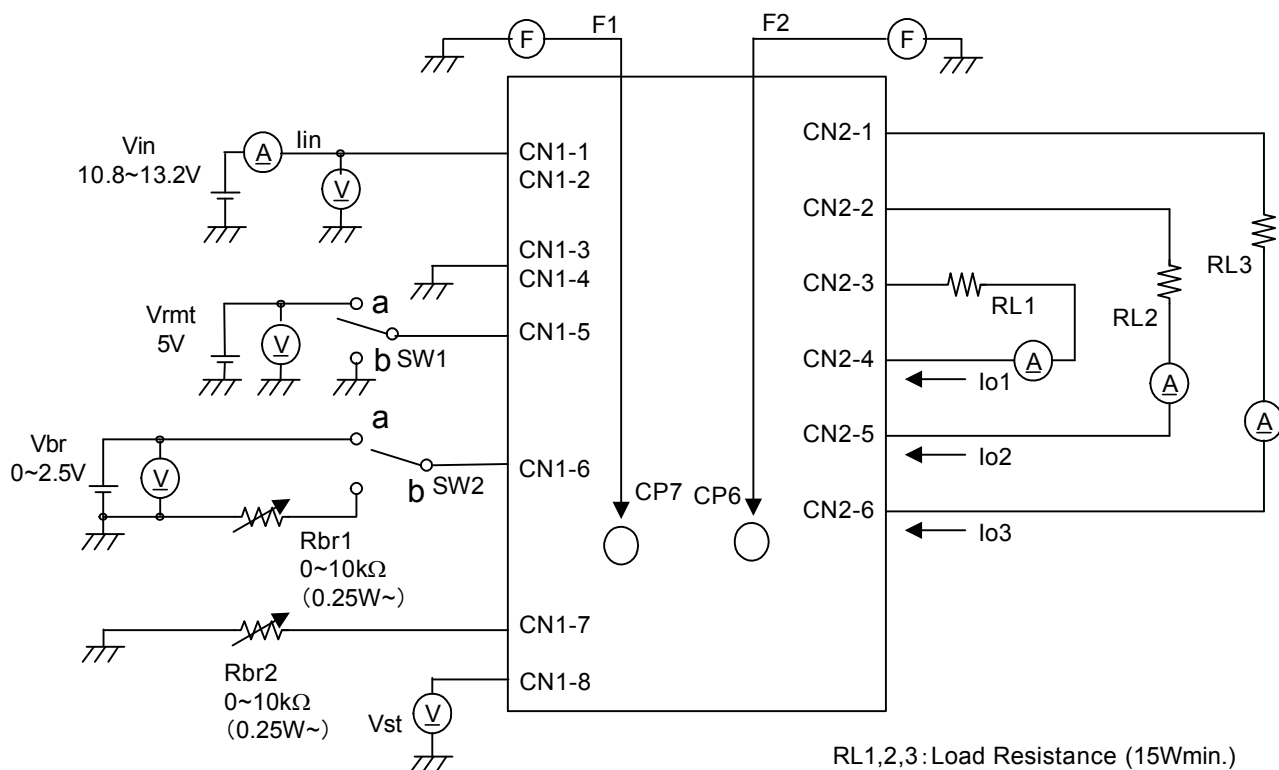

Note 8-5 SW1 function

SW1	Unit Behavior
a	Working
b	not Working
open	not Working

Note 8-6 SW2 function

SW2	Unit Behavior
a	PWM DC Dimming Vbr=0~2.5V
b	PWM Resistor Dimming Rbr=0~10kΩ

* Vbr=2.5V : Maximum Brightness
Rbr=10kΩ : Maximum Brightness

Note 8-7 Test Equipment

- Ⓧ : DC Voltage Meter (ADVANTEST R6452A or equivalent)
- Ⓐ : DC Current Meter (ADVANTEST R6452A or equivalent)
- Ⓧ : Frequency Counter (ADVANTEST R6452A or equivalent)

Note 8-8 Protection Circuit

Load Condition	Alarm Output (CN1-8)	Latch Function
steady state	0.5V max.	no latch-up
1string open	4.5V min.	no latch-up
All strings open	4.5V min.	no latch-up

Fig. 8-3 ALD-414012PJ126

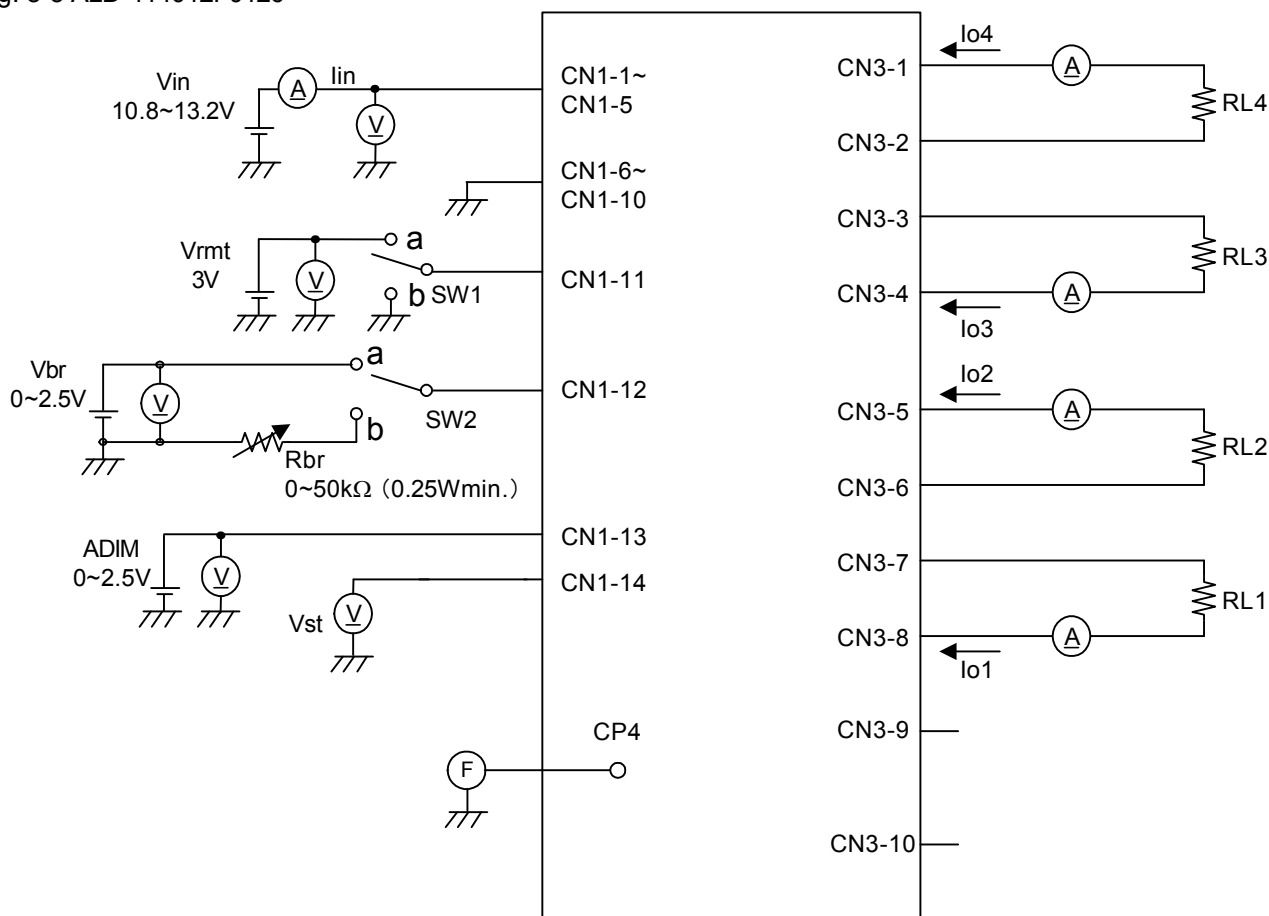

RL1~4: Load Resistance (15Wmin.)

Note 8-9 SW1 function

SW1	Unit Behavior
a	Working
b	Not Working
open	Not Working

Note 8-10 SW2 function

SW2	Unit Behavior
a	PWM DC Dimming Vbr=0~2.5V
b	PWM Resistor Dimming VR=0~50kΩ

* Vbr=0V : maximum brightness
Rbr=0Ω : maximum brightness

Note 8-11 Test Equipment

- (V) : DC Voltage Meter (ADVANTEST R6452A or equivalent)
- (A) : DC Current Meter (ADVANTEST R6452A or equivalent)
- (F) : Frequency Counter (ADVANTEST R6452A or equivalent)

Note 8-12 Protection Circuit

Load Condition	Alarm Output (CN1-8)	Latch Function
steady state	0.5V max.	no latch-up
1string open	4.5V min.	no latch-up
All strings open	4.5V min.	no latch-up

Fig. 8-4 ALD-514012PJ127

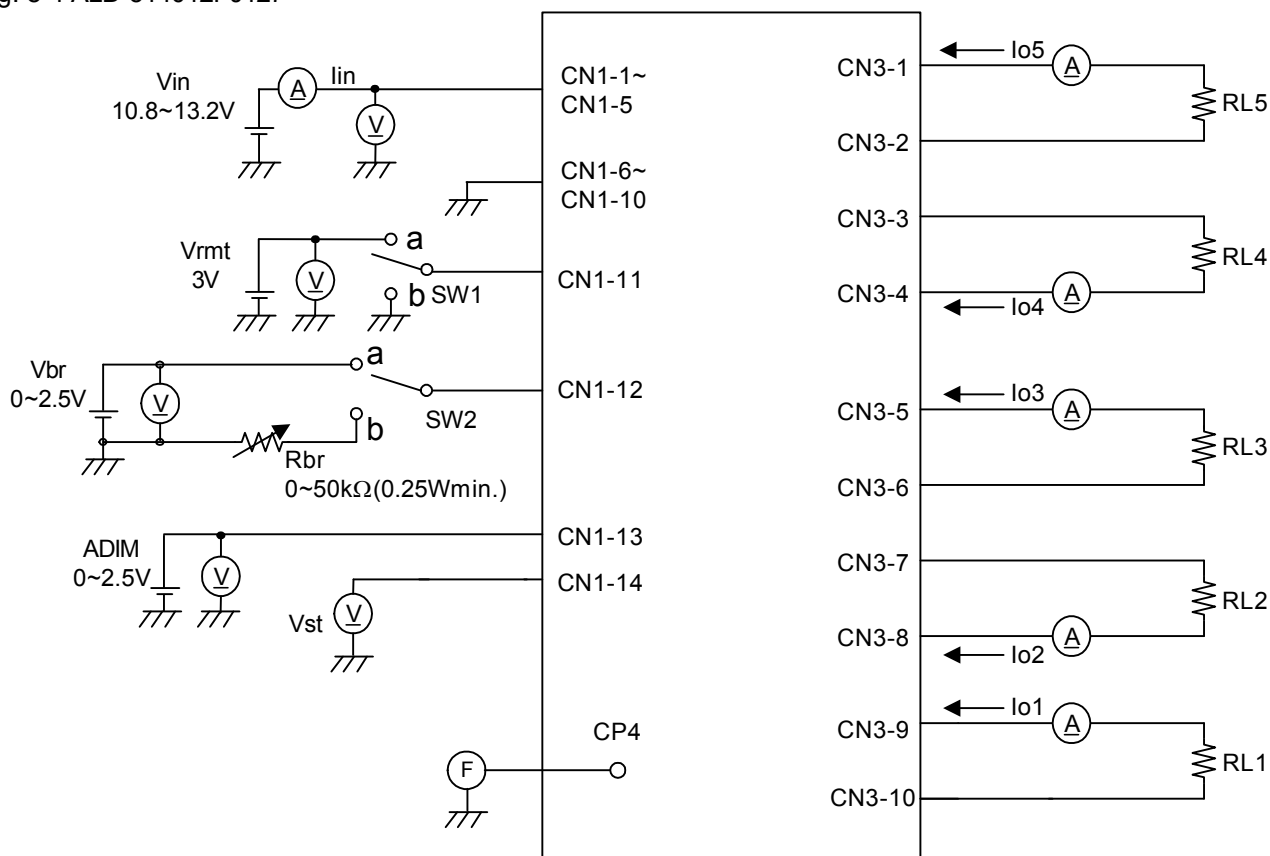

RL1~5: Load Resistance (15Wmin.)

Note 8-13 SW1 function

SW1	Unit Behavior
a	Working
b	Not Working
open	Not Working

Note 8-14 SW2 function

SW2	Unit Behavior
a	PWM DC Dimming Vbr=0~2.5V
b	PWM Resistor Dimming VR=0~50kΩ

* Vbr=0V : maximum brightness
Rbr=0Ω : maximum brightness

Note 8-15 Test Equipment

- (V) : DC Voltage Meter (ADVANTEST R6452A or equivalent)
- (A) : DC Current Meter (ADVANTEST R6452A or equivalent)
- (F) : Frequency Counter (ADVANTEST R6452A or equivalent)

Note 8-16 Protection Circuit

Load Condition	Alarm Output (CN1-8)	Latch Function
steady state	0.5V max.	no latch-up
1string open	4.5V min.	no latch-up
All strings open	4.5V min.	no latch-up



9 Other Caution Instructions

Please avoid to control dimming by Vrmt terminal. When you want to use dimming, please use Vbr or ADIM terminal.
When you handle the unit, please be careful to keep unit's components from coming in contact with anything.
This unit does not allow hot plugging. When the unit is operating don't plug in or plug out the connector.

10 Converter Layout Considerations

Please consider unit's layout to prevent long cabling. Don't use cable connector extensions.
In order to protect the inverter against vibration and shock, be sure to use all mounting holes when installing the inverter.
Please confirm the clearance between screw head and layout pattern.
Please confirm the connection between unit's GND and frame of back light.
Please refer to recommended mounting area Fig.11-1~Fig.11-3 before installing the unit.
If you put the unit on top of the back light directly, please isolate between the unit and back light.
Don't put the unit on top of the back light directly without isolation.

DC-DC Converter Unit ALD Series: Instruction Manual

Recommended Mounting Area

Fig.11-1 ALD-214012PJ111

*tolerance is $\pm 0.5\text{mm}$ unless otherwise specified

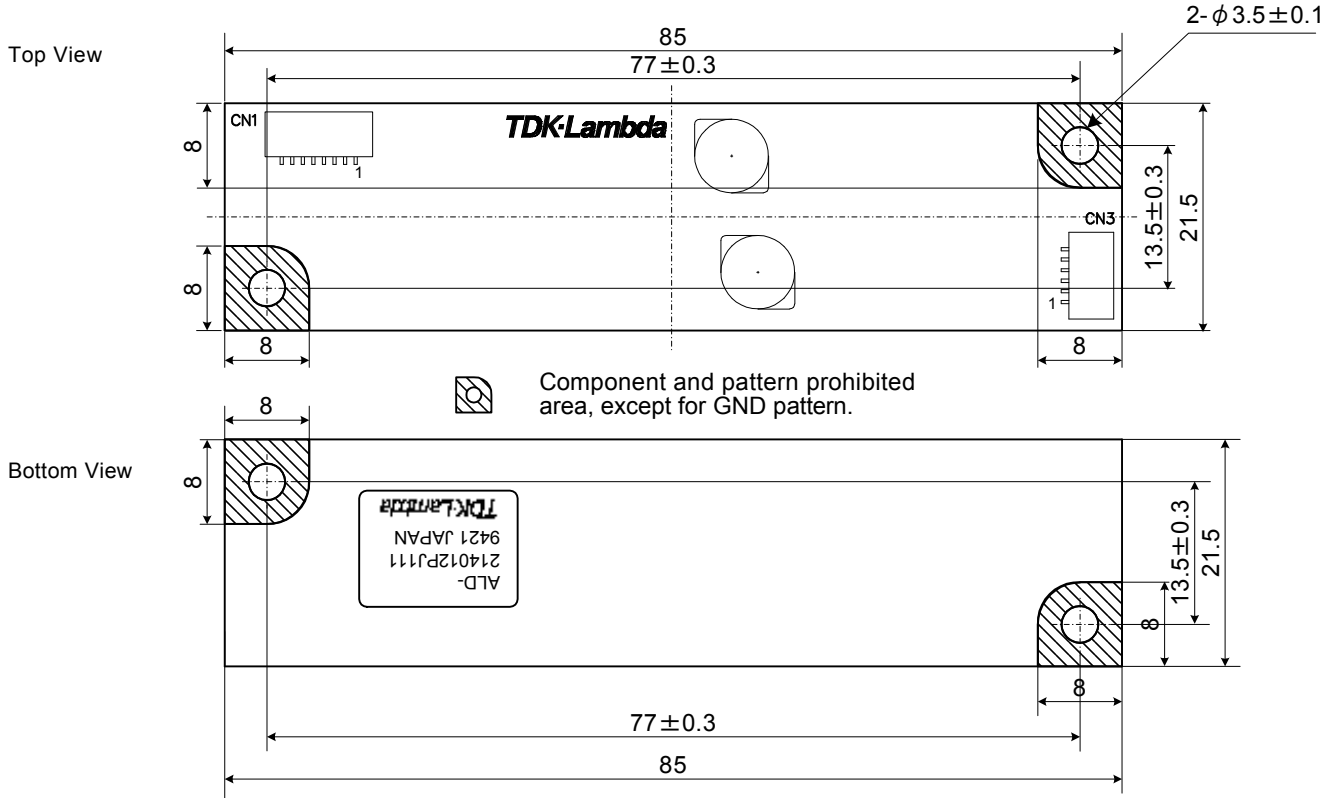
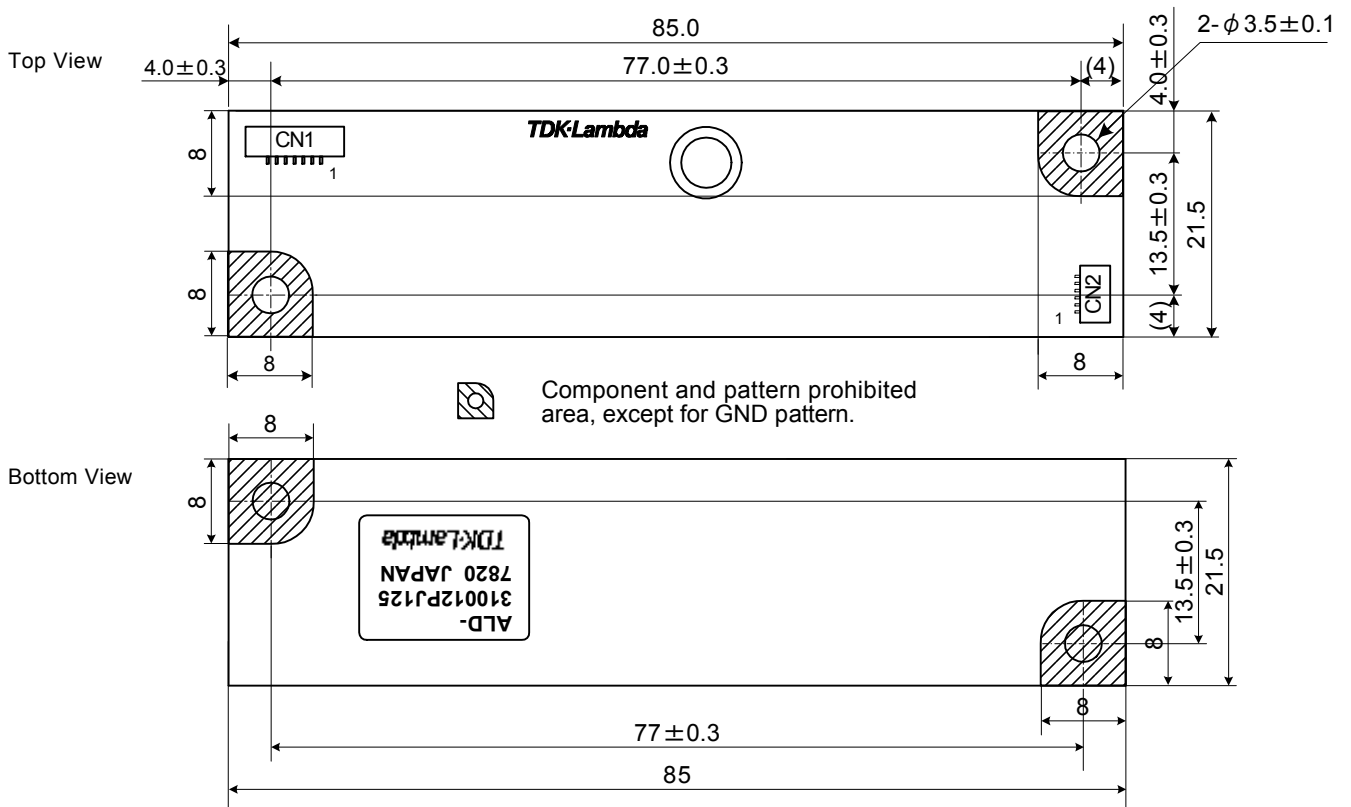

Fig.11-2 ALD-310012PJ125

*tolerance is $\pm 0.5\text{mm}$ unless otherwise specified





DC-DC Converter Unit ALD Series: Instruction Manual

Fig.11-3 ALD-414012PJ126, ALD-514012PJ127

*tolerance is $\pm 0.5\text{mm}$ unless otherwise specified



Component and pattern prohibited area, except for GND pattern.

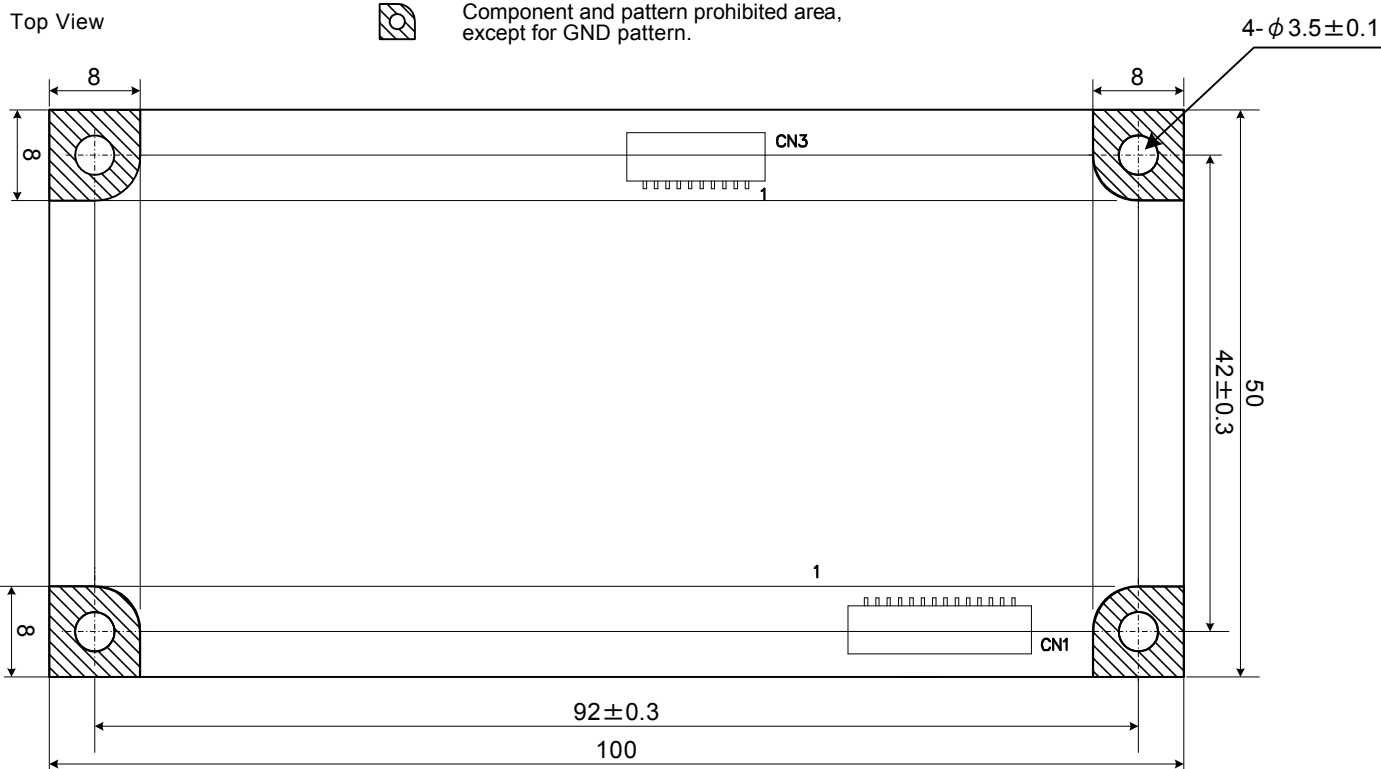

Bottom View

